

## SINYAL GALAXY TRAFFIC LIGHT

### Q200 SINGLE TRAFFIC LIGHT WITH POWER LED

Sinyal Galaxy Traffic Lights, With its superior energy efficiency and high performance, it is a trusted leader in traffic light solutions. Its durable structure, environmentally compatible design, and advanced LED system offer a long-lasting, efficient, and sustainable solution.

#### GENERAL FEATURES :

- > Lens Diameter: 200 mm
- > Body: Polycarbonate UV.
- > Body Color: Black-Gray-Orange
- > Impact Resistance: IR3
- > Ingress Protection: IP65
- > Vibration: Class AJ3
- > Warranty Period: 5 Years

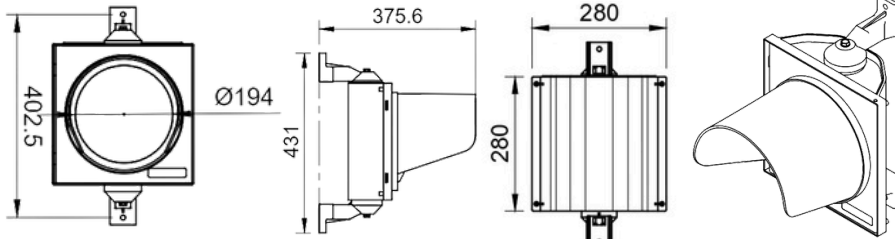
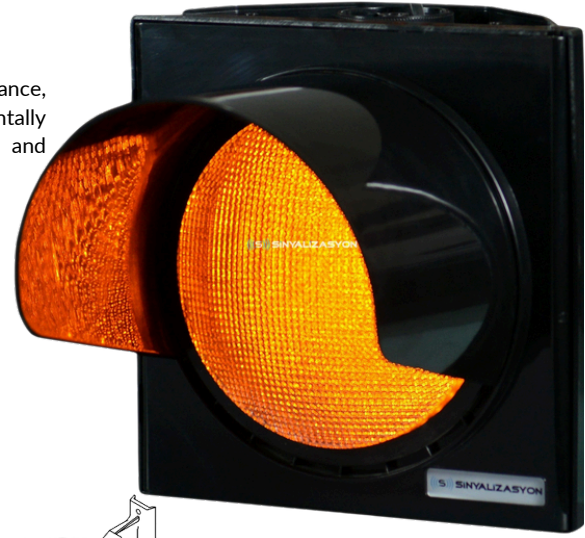

#### TECHNICAL SPECIFICATIONS :

- > Operating Voltage: 170-265 VAC
- > Operating Temperature: -40°C to +70°C
- > Power (Watt): < 10 W
- > Min. Shutdown Voltage: 90V
- > Reaction On/Off: < 50 ms
- > Total Harmonic Distortion (THD): < %20
- > Power Factor (pF): > 0,9
- > Dim Work: Optional
- > Number of LEDs : Ultra Bright LED for Red, Yellow, & Green
- > Light Power (Cd): Type W B3/2, B2/2
- > Signal Symbol: S1-S2
- > EMC: EN 50293
- > Phantom Class : 5
- > Light Distribution : 1/2.5
- > Certificate : TS EN 12368

#### PACKAGING AND DELIVERY DETAILS :

PRODUCT CODE	FRONT LENS	SIZE (mm)	FREQUENCY	WEIGHT (kg)	CABLE LENGTH
Q200GXPOL- R-Y-G 	Gray-Transparent- Colored	200mm	45-55 Hz	1,850kg	3,2m

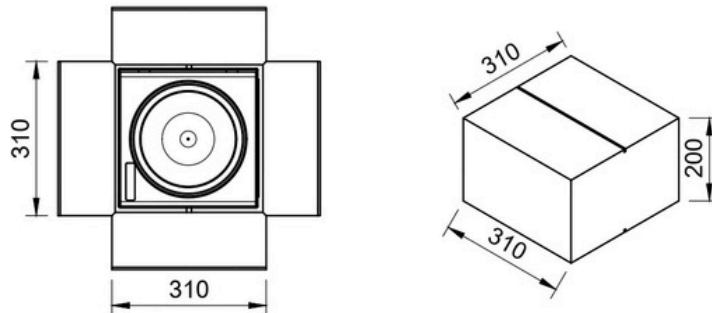

#### BOX CONTENTS:

- Traffic Light
- > Traffic Light
- > 2 Consoles
- > 2 M8 × 50 Bolts
- > 1 Visor

