

## SINYAL SARIX TRAFFIC LIGHT

### Q200 PEDESTRIAN TRAFFIC LIGHT WITH 5MM LED

Sinyal Sarix Traffic Lights, is a reliable leader in traffic signal solutions, offering superior energy efficiency and high performance. With its durable structure, environmentally adaptive design, and advanced LED technology, it provides a long-lasting, efficient, and sustainable solution.

#### GENERAL FEATURES;

- > Lens Diameter: 200 mm
- > Body: Polycarbonate UV.
- > Body Color: Black-Gray-Orange
- > Impact Resistance: IR3
- > Ingress Protection: IP65
- > Vibration: Class AJ3
- > Warranty: 5 Years.

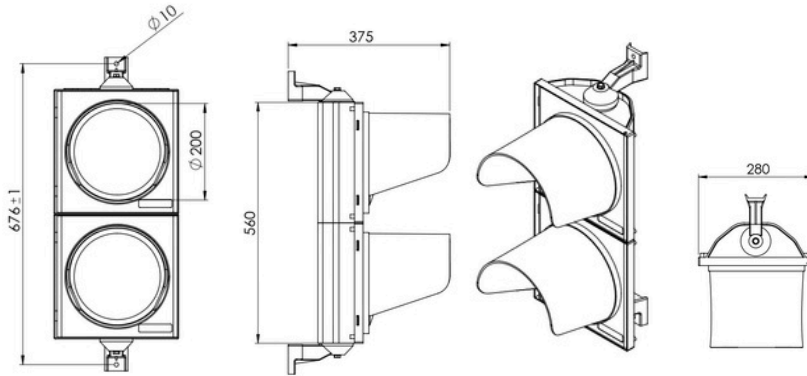

#### TECHNICAL SPECIFICATIONS;

- > Operating Voltage: 170-265 VAC
- > Operating Temperature: -40°C to +70°C
- > Power (Watt): < 10 W
- > Min. Shutdown Voltage: 90V
- > Reaction On/Off: < 50 ms
- > Total Harmonic Distortion (THD): < %20
- > Power Factor (pF): > 0,9
- > Dim Work: Optional
- > Number of LEDs : 90 and 87 Ultra Bright LEDs for red & green
- > Light Power (Cd): Type W B3/2
- > Signal Symbol: S1-S2
- > EMC: EN 50293
- > Phantom Class : 5
- > Light Distribution : 1/2.5
- > Certificate : TS EN 12368

#### PACKAGING AND DELIVERY DETAILS :

PRODUCT CODE	FRONT LENS	SIZE (mm)	FREQUENCY	WEIGHT (kg)	CABLE LENGTH
Q200DYF-R-Y-G	Gray-Transparent	200mm	45-55 Hz	3.370kg	3.2m

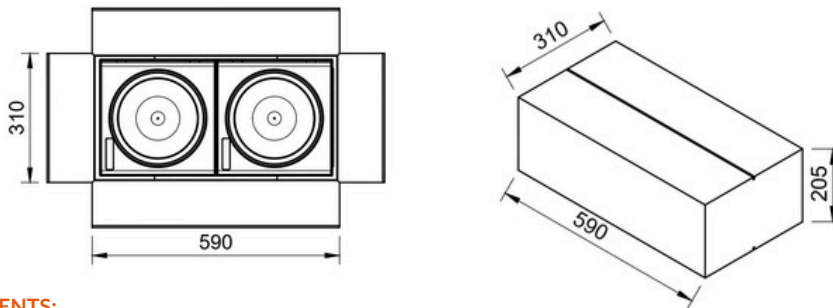

#### BOX CONTENTS:

##### Pedestrian Traffic Light

- > Pedestrian Traffic Light
- > 2 Consoles
- > 2 M8 × 50 Bolts
- > 2 Visors

