

## SINYAL SARIX TRAFFIC LIGHT

### Q300 SINGLE TRAFFIC LIGHT WITH 5MM LED

Sinyal Sarix Traffic Lights, is a reliable leader in traffic signal solutions, offering superior energy efficiency and high performance. With its durable structure, environmentally adaptive design, and advanced LED technology, it provides a long-lasting, efficient, and sustainable solution.

#### GENERAL FEATURES;

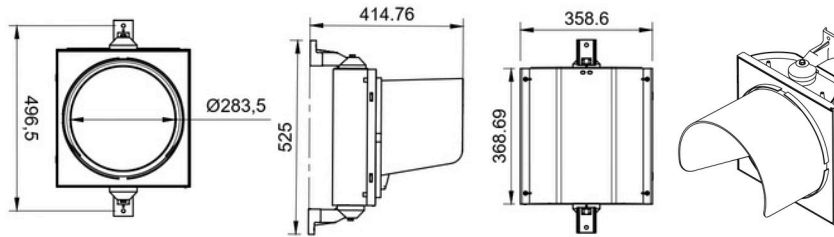

- > **Lens Diameter:** 300 mm
- > **Body:** Polycarbonate UV.
- > **Body Color:** Black-Gray-Orange
- > **Impact Resistance:** IR3
- > **Ingress Protection:** IP65
- > **Vibration:** Class AJ3
- > **Warranty:** 5 Years.



#### TECHNICAL SPECIFICATIONS;

- > **Operating Voltage:** 170-265 VAC
- > **Operating Temperature:** -40°C to +70°C
- > **Power (Watt):** < 10 W
- > **Min. Shutdown Voltage:** 90V
- > **Reaction On/Off:** < 50 ms
- > **Total Harmonic Distortion (THD):** < %20
- > **Power Factor (pF):** > 0,9
- > **Dim Work:** Optional
- > **Number of LEDs :** 251pcs Ultra Bright LED for red, yellow, green.
- > **Light Power (Cd):** Type N B3/2
- > **Signal Symbol:** S1-S2
- > **EMC:** EN 50293
- > **Phantom Class:** 5
- > **Light Distribution :** 1/2.5
- > **Certificate:** TS EN 12368

#### PACKAGING AND DELIVERY DETAILS;

PRODUCT CODE	FRONT LENS	SIZE (mm)	FREQUENCY	WEIGHT (kg)	CABLE LENGTH
   Q300MOL- R-Y-G	Gray- Transparent	300mm	45-55 Hz	3.000-3.200kg	3.2-12m

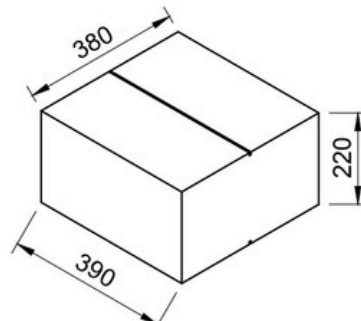
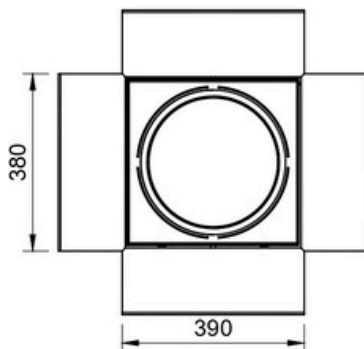

#### BOX CONTENTS;

- Single Traffic Light
- > Traffic Light
- > 2 Consoles
- > 2 M8 × 50 Bolts
- > 1 Visor

